

Adaption of Cable Accessories for Onshore and Offshore Substation



Impressum

Editor

PFISTERER Holding AG
Rosenstraße 44
73650 Winterbach
Phone +49 7181 7005-0
Fax +49 7181 7005-565
info@pfisterer.com
www.pfisterer.com

Published for

INMR World Congress 2015 in Munich
Cigre GCC 2015 in Jeddah

References

- [1] M. Freilinger, F. Bionda, F. Brodbeck
Advantages of Dry Type Cable Terminations up to 170 kV
INMR 2013 Vancouver
- [2] L. Colla, A. Reig Perez, E. Zaccone
EPR insulated cables for modern offshore systems
Jicable 2015
- [3] C. Späth, R. Grund, M. Zerrer
Hochseetaugliche Schnittstellen: Trockene, steckbare Anschluss-technik für HV- und
MV- Kabelsysteme auf offshore-Anlagen
HV-Symposium Stuttgart 2014
- [4] M. Freilinger
New Design of Dry Type Cable Terminations up to 170 kV
INMR journal Q3 2014

Content

Abstract	4
1 Introduction	4
2 Dry Outdoor Termination - Adaption for Substation	5
2.1 Adaption of mechanical design	5
2.2 Integrated surge arrester	6
2.3 Additional tests on dry type outdoor terminations and material	7
3 Dry Type Pluggable Solutions for On- and Offshore Application	8
3.1 Pluggable accessories	8
3.2 Dry type pluggable cable joints	8
3.3 Offshore certification and installation	10
4 Dry HV Cable Accessories for ultra-bendable EPR Cable	11
4.1 Ultra-bendable HV cables	11
4.2 Adaptation of dry type cable accessories for ultra-bendable HV cables	11
4.3 Special applications of dry type cable accessories for ultra-bendable HV cables	11
5 Conclusion	12

Abstract

Pluggable solutions for gas insulated switchgears (GIS) and transformers as well as dry outdoor terminations are well implemented since several years within high voltage cable systems.

A further evolution step has been created by adapting these accessories to perfectly fit into onshore substations by integrating surge arrester and cost effective designs and into offshore substation by offering dry pluggable joints to connect sea cable towards platform cable, designing offshore resistant systems or integrating ultra-bendable EPR cables with high flexible conductor for further space saving and withstand dynamic forces after installation.

2 Introduction

Over the last decades till today PFISTERER is an independent manufacturer of high voltage cable accessories from 24 kV up to 550 kV for various cable manufacturers worldwide.

Driven by easy and save installation as well as in service stability and good failure behaviour complete dry type outdoor cable terminations and dry pluggable solutions for GIS and transformers have been developed by PFISTERER more than 25 years ago.

Following the highest demand of such cable accessories within onshore and offshore substation a special adaptation for a wide application range has been realized. This range is covering pluggable terminations for GIS and transformer application including off shore certification, pluggable solid epoxy-joints, pluggable surge arrester, installation- and cost optimized dry outdoor terminations including an option for integrating a surge arrester and the possibility of installing all products onto ultra-bendable HV cables with EPR insulation.

The adaptation of a high voltage component for special application requires a verification of the design, which is one of the most important steps during the development and qualification process. The big challenge for HV cable accessories is to be able to work for different cable constructions, since these may vary depending on cable manufacturer, customer requirements and operating conditions.

In order to verify the accessories design a significant amount of internal tests as well as official qualifications witnessed by or in a third party HV laboratory have been performed.

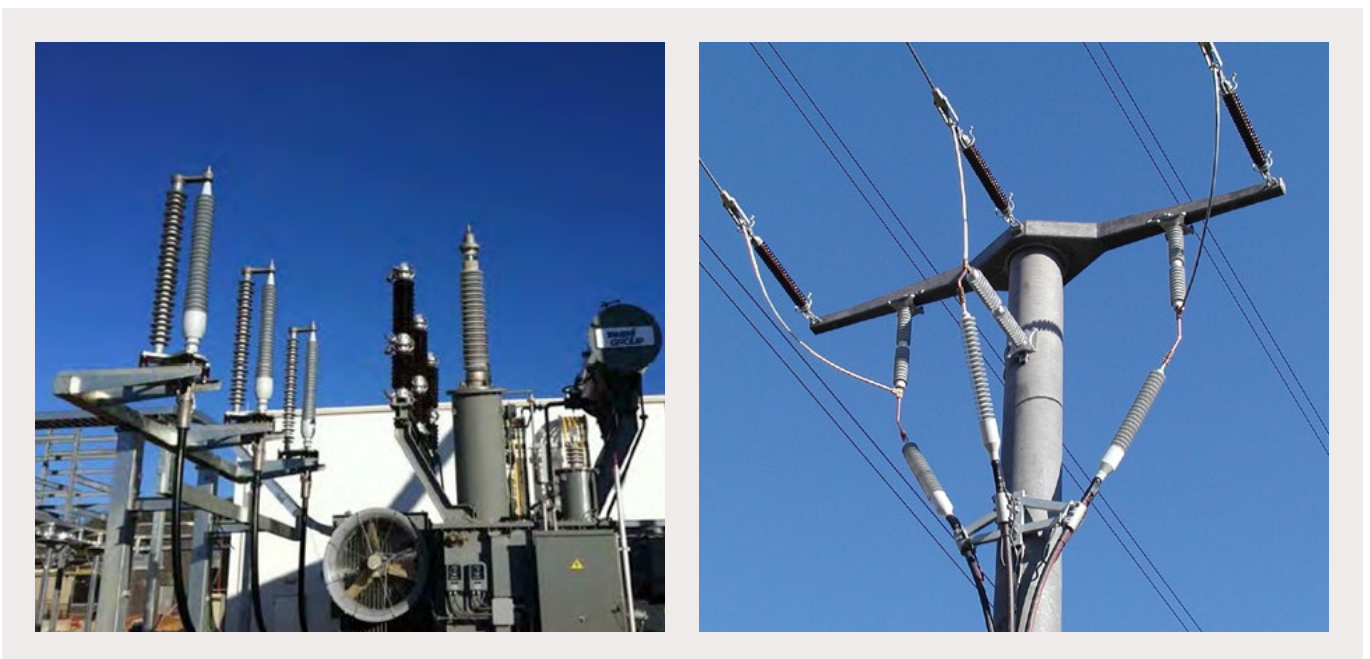

Fig. 1: Flexible and supported outdoor terminations up to 170 kV (complete dry type)

3 Dry Outdoor Termination - Adaption for Substation

3.1 Adaption of mechanical design

Dry type terminations are well known for many advantages:

- Dry type design (no oil or gas insulation)
- Easy and safe installation on the ground
- Reduced installation costs
- „Explosion proved“ behaviour

They can be divided into the two groups of flexible or self-supported terminations for various applications [1].

Both versions are well known on the market whereas the flexible termination is one of the most cost effective solutions and the supported termination gives maximum mechanic stability including a rotation system for lifting on overhead line towers.

In a first step the adaptation to substation applications is a combination of both advantages. The flexible termination can be installed on the ground onto the cable. Afterwards it is lifted onto its already prepared support with an open baseplate. Due to a limited height up to 6 m and less cable weight an optimized solution regarding mechanical design, easy installation and cost effectiveness has been created.



Fig. 3: Dry outdoor termination for substation application

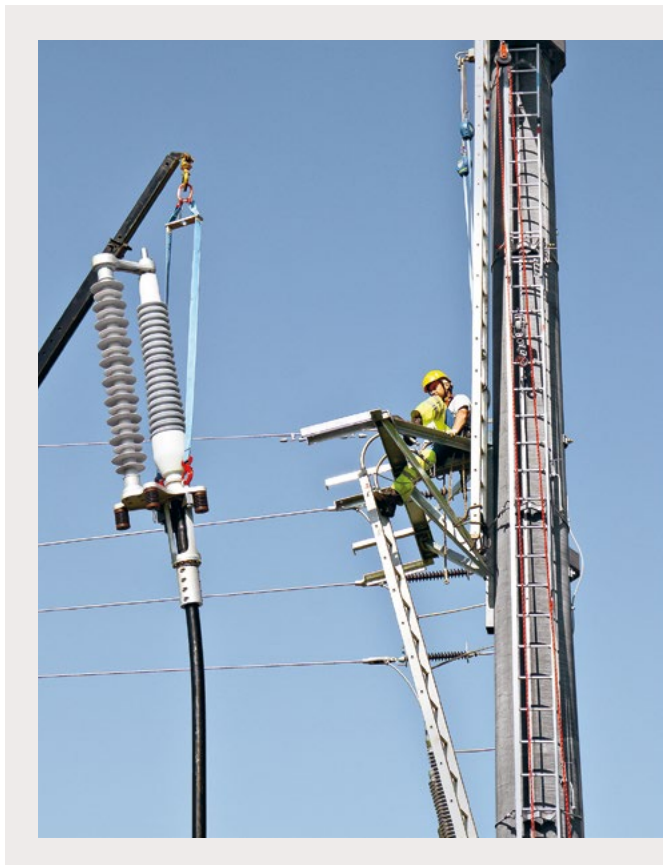
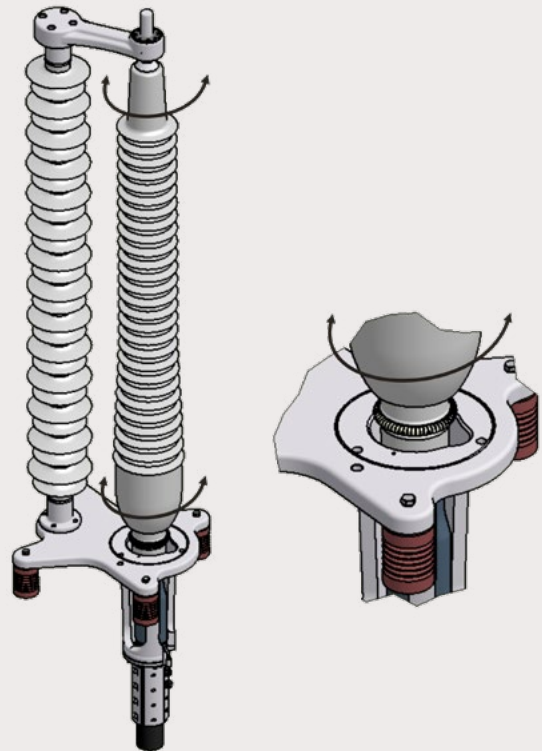

Fig. 2: 360° rotating support design and lifting of 170 kV dry type outdoor termination



3.2 Integrated surge arrester

In a second step an option has been created for a combined product. Replacing the post insulator by integrating a surge arrester offers significant space and cost saving potential during a substation design. The combined product requires the space of one conventional termination only and is fixed on the same support.

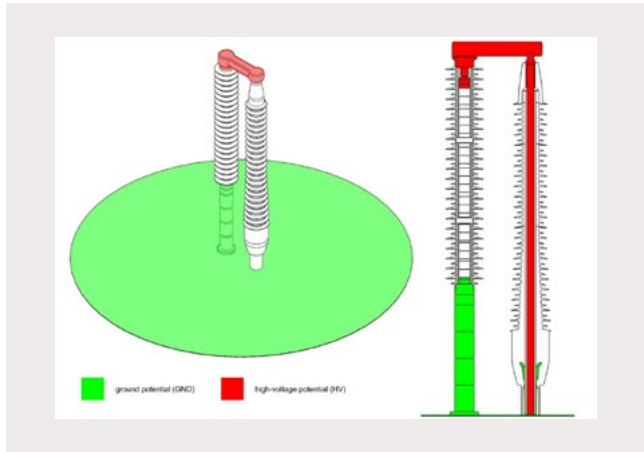

Fig. 4: Design of dry cable termination combined with a surge arrester

The cable screen is no longer connected to the base plate of such a combined product as a surge arrester needs a direct earthing point. Bonding of cable screen can be applied at the bottom of the termination or via a link box.

For evaluating an ideal arrangement of the combined product a FEM-calculation has been done with two different FEM-programs to limit calculation errors to a minimum.

Main findings of these calculations have been:

- The distribution of the electric potential along metal oxide discs at the surge arrester is more homogenous and the voltage along the upper discs is reduced by the influence of the cable termination. This effect gets stronger by shorter distances.
- The electric field strength along the silicone sheds of the surge arrester normally is higher at the upper part next to high voltage potential. Depending on smaller distances towards a cable termination this effect can be equalized or even inverted (higher electric field on the sheds at the bottom).
- By smaller distances between surge arrester and cable termination the electric field strength at the cable termination is forced from the upper part towards the lower part and is significantly higher at the area close to the surge arrester.

All these findings lead to the result that there is an optimum distance for the arrangement of the combined product.

Beside an influence on electric field distribution of such a combined product different customer requirements have to be considered. Solid earthed systems as well as coil earthed systems can be found in the world of energy transmission which leads to two different surge arrester solutions. Additional to two earthing systems one is facing different philosophies within network operators.

The “safety first and money is no issue” opinion is focusing on tube type surge arresters, which have an explosion resistant design even in case of a failure. Additional they offer a high cantilever force which supports the cable termination on a high mechanical level. These positive aspects of course need a higher monetary effort.

Cost effectiveness is leading towards a cage type surge arrester. During a seldom occurring incident, in worst case this can harm the function of the cable termination and both products have to be replaced. The lower cantilever forces compared to a tube type surge arrester are still high enough to ensure a mechanical proper working combined product.

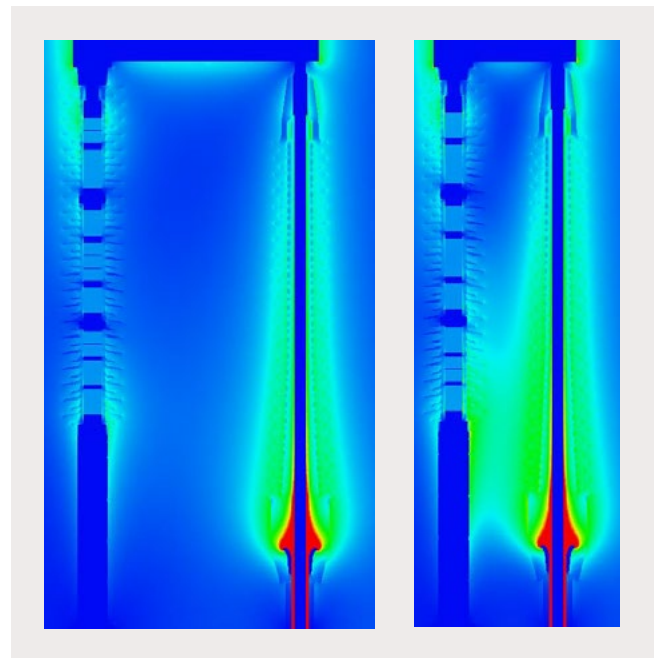

Fig. 5: FEM calculation at various distances of a dry termination combined with a surge arrester

3.3 Additional tests on dry type outdoor terminations and material

Standard tests of dry type outdoor terminations are normally performed according to IEC 60840 or IEC 62067. Due to the increasing demand on this type of accessories especially for substation projects, additional tests have been performed in order to satisfy special customer requirements. One of them is the salt fog withstand test according to UX LK 208 Rev. 01 and based on IEC 60507 (Second edition 1991-04), which has been successfully passed for the high voltage cable termination type EST170-C53L (Figure 6) confirming the required specified salinity of 112 kg/m^3 at a test voltage of 98.1 kV ($170 \text{ kV} / \sqrt{3}$).



Fig. 6: HV cable termination type EST170-C53L during salt fog withstand

The same termination type EST170-C53L mentioned above has also been subjected to and successfully passed a wet power frequency withstand voltage test according to UX LK 208 Rev. 01, which consists on the application of $2.5 U_0$ (218 kV) during 15 minutes while the test object is under artificial rain as stated in IEC 60060-1.

Moreover, during the development stage, a test for the evaluation of the resistance to tracking and erosion has been performed according to IEC60587 (Third edition, 2007-05) giving satisfying results [1].



Fig. 7: HV cable termination type EST170-C53L during wet power frequency withstand voltage test

The mechanical behaviour of the self-supported termination has been verified several times through specific tests on the support insulator and on the complete termination [1].



Fig. 8: Material samples after test for the evaluation of the resistance to tracking and erosion

4 Dry Type Pluggable Solutions for On- and Offshore Application



Fig. 9a: Offshore wind power generation application

4.1 Pluggable accessories

Since many years pluggable terminations, bushings and further accessories are a successful and significant part of the high voltage cable accessories world. During the last years the product range has been enlarged for further applications and been driven towards highest voltage levels (designed up to 550 kV).

Combining the three worlds of transformer manufacturer (testing IEC 60137, housing EN 50299), GIS manufacturer (testing IEC 62271 203, housing IEC 62271 209) and cable manufacturer (testing IEC 60840 and IEC 62067) it is necessary to understand all needs of and differences between them. In order to combine and fulfil all requirements a wide product range is needed.

- Pluggable termination (separable socked and plug)
- Pluggable surge arrester
- Pluggable SF₆ filled back to back joint
- Pluggable dry cast resin joint
- Covering disc for pollution protection of the socked
- Protective cap for pollution protection of the plug
- Dummy plug for voltage insulation
- Earthing and short circuit device
- Earthing cap
- Current testing cap
- Gas-insulated blind cover

4.2 Dry type pluggable cable joints

Due to the increasing demand on HV cable accessories for offshore applications, a new CONNEX dry type pluggable joint (back-to-back joint) has been developed. This kind of accessory combines the advantages of standard dry type pluggable terminations and joints, and easily allows the connection between different cables. The main benefits are:

- Dry type design (no oil or gas insulation)
- Pluggable connection
- Fast and easy installation with CONNEX connectors
- Compact design
- Connection of two different type and sizes of cable
- Resistant to salt water and UV radiation
- Epoxy body fully offshore proved

Figure 9a and 9b show an example of exploitation of the advantages of this type of accessory using it for the connection between sea and tower cable in an offshore wind power generation application.



Fig. 10: CONNEX dry type pluggable joint

In order to fulfil the growing requirements on HV cable systems, the above mentioned advantages allow also the use of the dry type back-to-back joint for other applications:

- Refurbishing of old HV cable system through connection of old (already installed) and new cable
- Temporary installation for construction sites
- Backup solution
- Connection between test equipment and test objects (e.g. during commissioning)

The construction has been successfully proved and certified for offshore use by several design tests and additional type tests according to IEC 60840 for voltage levels up to $U_m = 100$ kV and conductor cross sections up to 1600 mm². Moreover, this product for $U_m = 170$ kV will be soon available, since the development is already on-going.



Fig. 11: Setup for the electrical test of the dry type back-to-back joint



Fig. 9b: Connection between sea and tower cable in an offshore wind power generation application

4.3 Offshore certification and installation

For offshore substations environmental conditions as well as special application during project handling has to be considered. Beside saltwater conditions and high UV radiation there is limited space available and the whole substation has to be installed and fully tested onshore and later is shifted offshore where the sea cable part finally is connected. A full product family of pluggable systems on medium and high voltage level is mandatory.

Pluggable cable accessories offer a fully encapsulated solution for offshore substations. The outer part has to be touch prove and on ground potential. All Metal and heat shrink parts have to withstand harsh salt fog conditions (DIN 81243) and high UV radiation.



Fig. 12: Testing of offshore substation Borkum 2



Fig. 14: GL offshore certificate for CONNEX Size 4

An offshore certification has been given for PFISTERER encapsulated pluggable system by Germanischer Lloyd, a company who classifies material and system for maritime application (Figure 14). Beside the design and classification of materials this includes salt fog tests and ageing tests during UV radiation.

Pluggable cable accessories require less space and additionally offer the possibility of separating parts of the system as transformers, gas insulated switchgear or cable system. Installation and testing of these items can be done individually and the connection of the sea cable finally can be done with a minimum effort towards a fully tested substation.



Fig. 13: High and medium voltage connection on transformer on offshore substation Alpha Ventus

5 Dry HV Cable Accessories for ultra-bendable EPR Cable

5.1 Ultra-bendable HV cables

Ultra-bendable high voltage cables are suitable especially for offshore applications, where high flexibility, very small bending radii and mobile or fixed installation are required [2]. Moreover, due to the mentioned features, this cable type could be used for onshore substations and other applications, where the available space is limited.

5.2 Adaptation of dry type cable accessories for ultra-bendable HV cables

In order to guarantee a proper jointing and termination of ultra-bendable HV cables, it was necessary to implement in standard dry type high voltage cable accessories a new mechanical torque connector type „SICON“ especially developed for highly flexible copper conductors. The behaviour and design have been successfully verified with a test based on IEC 61238-1 (Second edition, 2003-05) for 800 mm² conductor cross section (Figure 15).

Additionally, the performance of high voltage cable joints, outdoor terminations and CONNEX dry type pluggable connectors installed on an ultra-bendable HV cable has been successfully verified through several design and type tests according to IEC 60840 for $U_m = 170$ kV and a conductor cross section up to 800 mm².

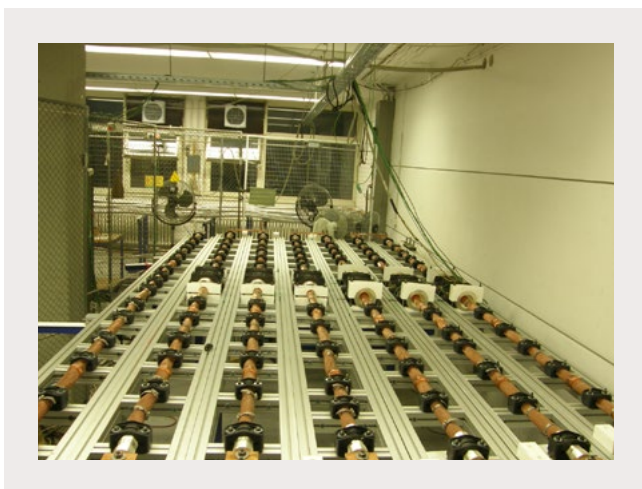

Fig. 15: Setup for conductor connector electrical tests based on IEC 61238-1 (Second edition, 2003-05)



Fig. 16: Type test setup for $U_m = 170$ kV and 800 mm² copper conductor according to IEC 60840

5.3 Special applications of dry type cable accessories for ultra-bendable HV cables

Ultra-bendable high voltage cables and dry type pluggable terminations together combine the advantages of the compact and flexible design, and are therefore also suitable for:

- Temporary installation for construction sites
- Backup solution
- Connection between test equipment and test objects (e.g. during commissioning)

An example of the exploitation of the above mentioned benefits are cable links equipped with dry type pluggable connectors or outdoor terminations, allowing the transportation on a drum mounted on a trailer (Figure 17).



Fig. 17: Cable link on trailer for temporary installation

1 Conclusion

New system needs represent a challenge for HV cables and accessories. In order to fulfil the requirements in a reasonable time, without significant influence on the project duration and costs, know-how, flexibility and product modularity play a major role.

The „EST“ dry type HV cable termination and the „CONNEX“ dry type pluggable connector have shown, to be a very good solution for substation applications. Thanks to engineering know-how, modular products and robust design it was possible to implement successfully new features such as surge arrester, connection of ultra-bendable HV cables and dry type pluggable jointing in a very short time.

PFISTERER Kontaktsysteme GmbH

Rosenstraße 44
73650 Winterbach
Germany
Phone: +49 7181 7005 0
Fax: +49 7181 7005 565
info@pfisterer.com
www.pfisterer.com

PFISTERER Switzerland AG

Gotthardstrasse 31
6460 Altdorf
Switzerland
Phone: +41 41 874 75 75
Fax: +41 41 874 75 76
power@ixosil.ch
www.pfisterer.com



In 1921, Karl Pfisterer founded his factory in Stuttgart for special electrical products with the aim of improving the world of power transmission. The PFISTERER Group has pursued this goal of quality and technological leadership for more than 100 years. Today, PFISTERER is one of the world's leading specialists and system suppliers for energy infrastructure – with a complete range of cable accessories, overhead line technology and components along the entire transmission chain from power generation to consumption. With state-of-the-art manufacturing processes and 1,200 employees at 18 international locations, PFISTERER not only connects the power grids of today and tomorrow, but also makes an important contribution to a sustainable and secure energy supply.